



2.5GHz 1,6/5.6 N/O S.P.3 T. SWITCH

OPTIONS : INDICATOR /BCD DECODER /SUPP.DIODES

**RF CHARACTERISTICS**

NUMBER OF WAYS : 3  
 FREQUENCY RANGE : 0 - 2.5 GHz  
 IMPEDANCE : 75 Ohms

FREQUENCY (GHz)	0 - 1	1 - 2.5
V.S.W.R <=	1.20	1.30
INSERT. LOSS <=	0.20 dB	0.30 dB
ISOLATION >=	80 dB	70 dB
AVER. POWER (*)	400 W	240 W

**ELECTRICAL CHARACTERISTICS**

ACTUATOR : NORMALLY OPEN  
 NOMINAL CURRENT AT 25° C (±10%) : 102 mA  
 ACTUATOR VOLTAGE (Vcc) : 28V (24 to 30V) / NEGATIVE COMMON  
 TERMINALS : solder pins (250°C max./30 sec.)  
 INDICATOR RATING : 1 W / 30 V / 100 mA  
 BCD INPUTS (E) - High level : 3.5 to 5.5V / 800µA at 5V  
 - Low level : 0 to 1.5V / 20µA at 0.8V

**MECHANICAL CHARACTERISTICS**

CONNECTORS : 1,6/5.6 female per IEC 169-13  
 LIFE : 2.000.000 cycles per position  
 SWITCHING TIME (nominal voltage;25° C) : < 15 ms  
 CONSTRUCTION : splashproof  
 WEIGHT : < 220 g

**ENVIRONMENTAL CHARACTERISTICS**

OPERATING TEMPERATURE RANGE (°C) : -25 , +70  
 STORAGE TEMPERATURE RANGE (°C) : -40 , +85

(\* : average power at 25° C per RF path)

4112-9212 This information is given as an indication. In the continual goal to improve our products, we reserve the right to make any modifications judged necessary

**DRAWING**

General tolerance: ± 0,5 mm

**R573 913382**

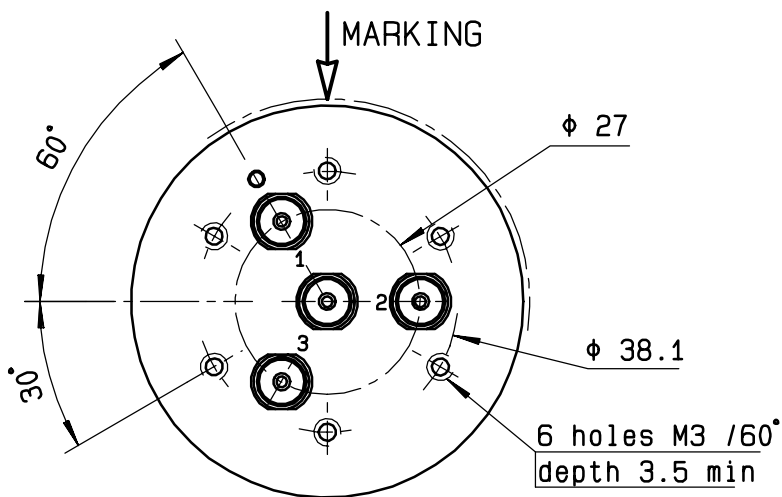

E3	E2	E1	RF continuity	Ind.
0	0	0	LAST SELECTED POS	--
1	1	1	ALL PORTS OPEN	--
0	0	1	IN ↔ 1	D.E
0	1	0	IN ↔ 2	D.F
0	1	1	IN ↔ 3	D.G

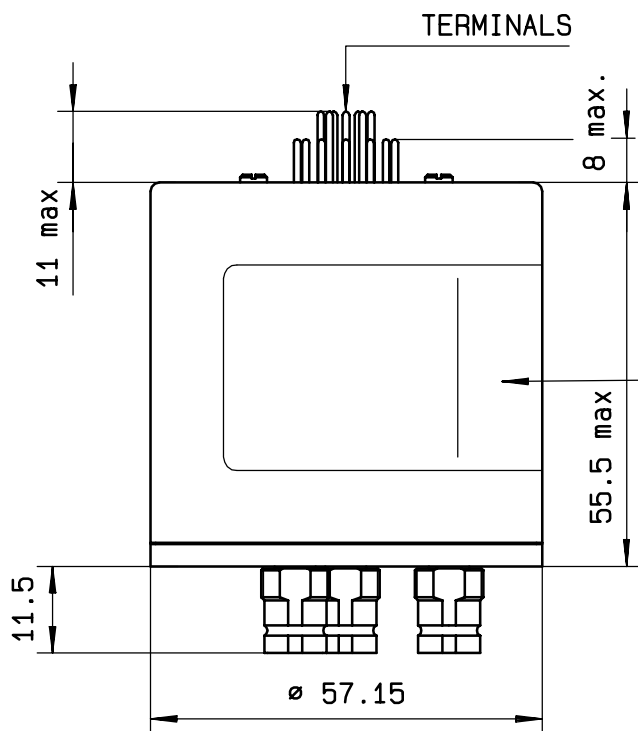

MARKING TOP VIEW (TERMINALS)

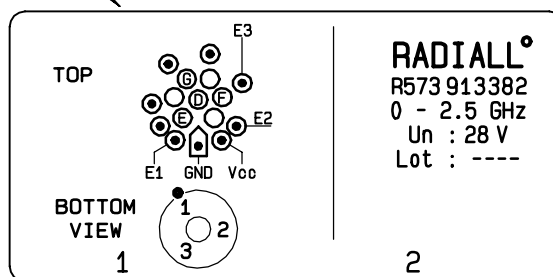

**SCHEMATIC DIAGRAM**

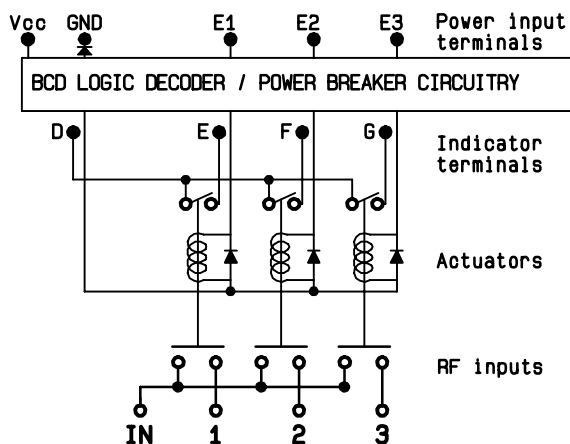

4113-9212 This information is given as an indication. In the continual goal to improve our products, we reserve the right to make any modifications judged necessary